

www.raisecom.com

RAX721-T-XF (C)
Product Description
(Rel_01)

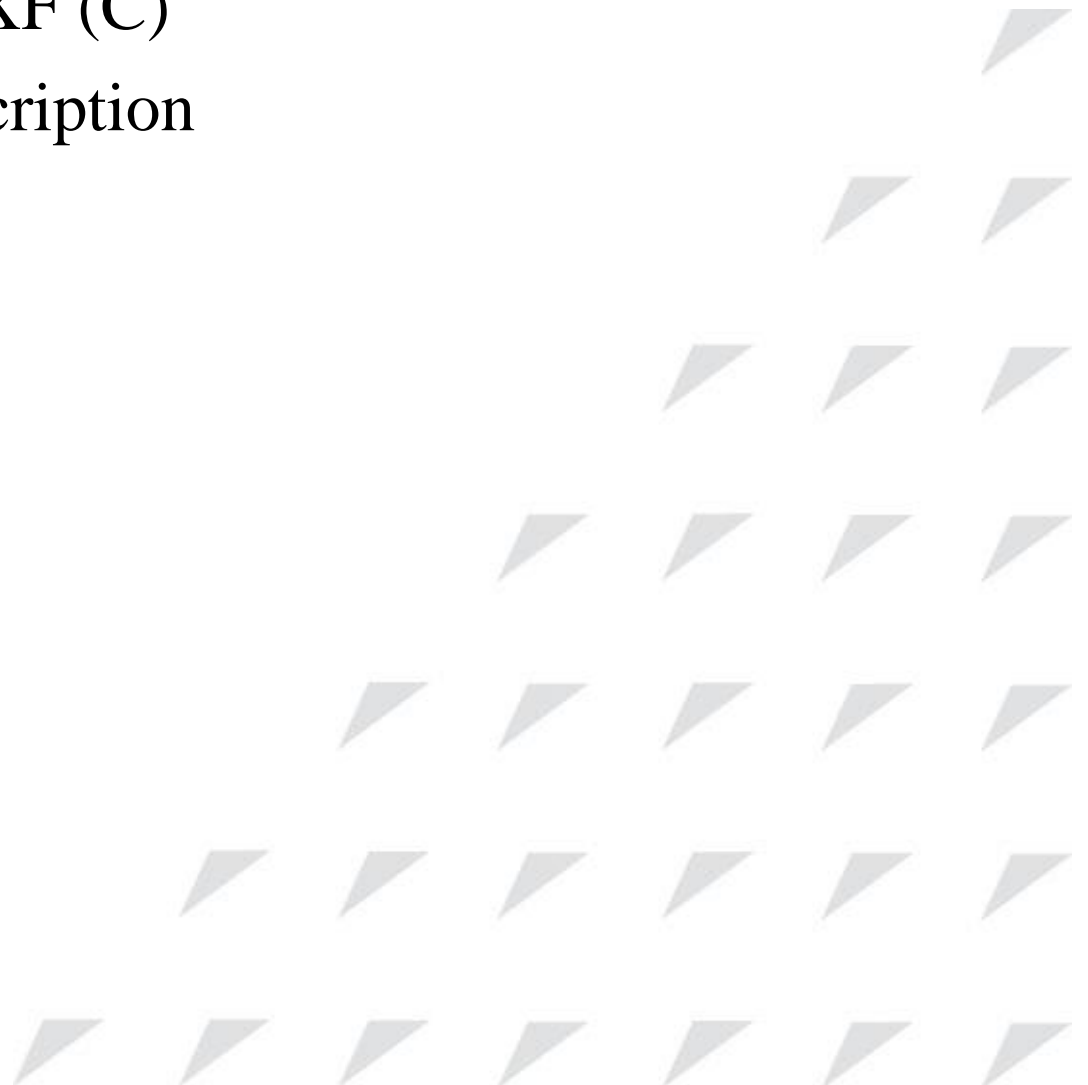

Raisecom Technology Co., Ltd. provides customers with comprehensive technical support and services. For any assistance, please contact our local office or company headquarters.

Website: <http://www.raisecom.com>

Tel: 8610-82883305

Fax: 8610-82883056

Email: export@raisecom.com

Address: Raisecom Building, No. 11, East Area, No. 10 Block, East Xibeiwang Road, Haidian District, Beijing, P.R.China

Postal code: 100094

Notice

Copyright © 2024

Raisecom

All rights reserved.

No part of this publication may be excerpted, reproduced, translated or utilized in any form or by any means, electronic or mechanical, including photocopying and microfilm, without permission in Writing from **Raisecom Technology Co., Ltd.**

RAISECOM is the trademark of Raisecom Technology Co., Ltd.

All other trademarks and trade names mentioned in this document are the property of their respective holders.

The information in this document is subject to change without notice. Every effort has been made in the preparation of this document to ensure accuracy of the contents, but all statements, information, and recommendations in this document do not constitute the warranty of any kind, express or implied.

Preface

Objectives

This document describes the RAX721-T-XF in aspects of overview, network applications, product features, functions, system structure, and technical specifications.

Versions





The following table lists the product versions related to this document.

Product name	Product version	Hardware version
RAX721-T-XF	P300R001	C.00 or later

Conventions

Symbol conventions

The symbols that may be found in this document are defined as below.

Symbol	Description
 Warning	Indicate a hazard with a medium or low level of risk which, if not avoided, could result in minor or moderate injury.
 Caution	Indicate a potentially hazardous situation that, if not avoided, could cause equipment damage, data loss, and performance degradation, or unexpected results.
 Note	Provide additional information to emphasize or supplement important points of the main text.
 Tip	Indicate a tip that may help you solve a problem or save time.

General conventions

Convention	Description
Times New Roman	Normal paragraphs are in Times New Roman.
Arial	Paragraphs in Warning, Caution, Notes, and Tip are in Arial.
Boldface	Buttons and navigation path are in Boldface .
<i>Italic</i>	Book titles are in <i>italics</i> .
Lucida Console	Terminal display is in Lucida Console.
Book Antiqua	Heading 1, Heading 2, Heading 3, and Block are in Book Antiqua.

Change history

Updates between document versions are cumulative. Therefore, the latest document version contains all updates made to previous versions.

Issue 01 (2024-06-30)

Initial commercial release

Contents

1 Overview.....	1
1.1 Introduction.....	1
1.2 Network applications.....	2
1.2.1 MAN pre-aggregation comprehensive access.....	2
1.3 Ordering information.....	3
1.3.1 Ordering information	3
2 System structure	4
2.1 Hardware structure	4
2.1.1 Appearance.....	4
2.1.2 Interface types	6
2.1.3 LEDs	8
2.1.4 Power supplies	9
2.2 Software structure	10
3 Technical specifications.....	11
3.1 Overall specifications	11
3.2 Interface specifications.....	12
3.2.1 10 Gbit/s optical interfaces.....	12
3.2.2 1000 Mbit/s optical interfaces	13
3.2.3 SNMP interfaces	13
3.2.4 Console interface	13
3.3 Laser safety class.....	14
3.4 Reliability specifications	14
3.5 EMC	15
3.6 Safety standards	15
3.7 Environmental requirements	15
3.7.1 Storage environment	15
3.7.2 Transport environment	17
3.7.3 Operating environment	19
4 Appendix	21
4.1 Cables.....	21

4.1.1 Fiber	21
4.1.2 Ethernet cable.....	22
4.1.3 USB configuration cable	25
4.1.4 RS232 configuration cable.....	27
4.1.5 DC power cable.....	28
4.1.6 AC power cable.....	29
4.1.7 Ground cable.....	31
4.2 Terms.....	33
4.3 Acronyms and abbreviations	39

1 Overview

This chapter describes basic information about the RAX721-T-XF, including the following sections:

- Introduction
- Network applications
- Ordering information

1.1 Introduction

The RAX721-T-XF is an access aggregation device used in packet-switched networks to meet the needs of multi-interface access, 10 Gigabit Network Interface Device (NID), and mobile backhaul services. The RAX721-T-XF can be connected upstream to the Raisecom iTN8000 or packet network device from other vendors, and manage and control end-to-end services.

The RAX721-T-XF provides dual power supplies for backup. Table 1-1 lists the device model.

Table 1-1 RAX721-T-XF model

Model	Description
RAX721-T-XF	<ul style="list-style-type: none">• Four 10G/1G bit/s uplink interfaces (optical interface)• Twenty-four 10G/1G/100M bit/s downlink interfaces (optical interface)• USB Console interface and RJ45 Console interface• SNMP interface, which supports out-of-band network management• Dual 220 VAC, dual -48 VDC, and hybrid 220 VAC and -48 VDC• 1U high, 19-inch wide chassis• Clock synchronization, SyncE, and IEEE 1588v2

1.2 Network applications

1.2.1 MAN pre-aggregation comprehensive access

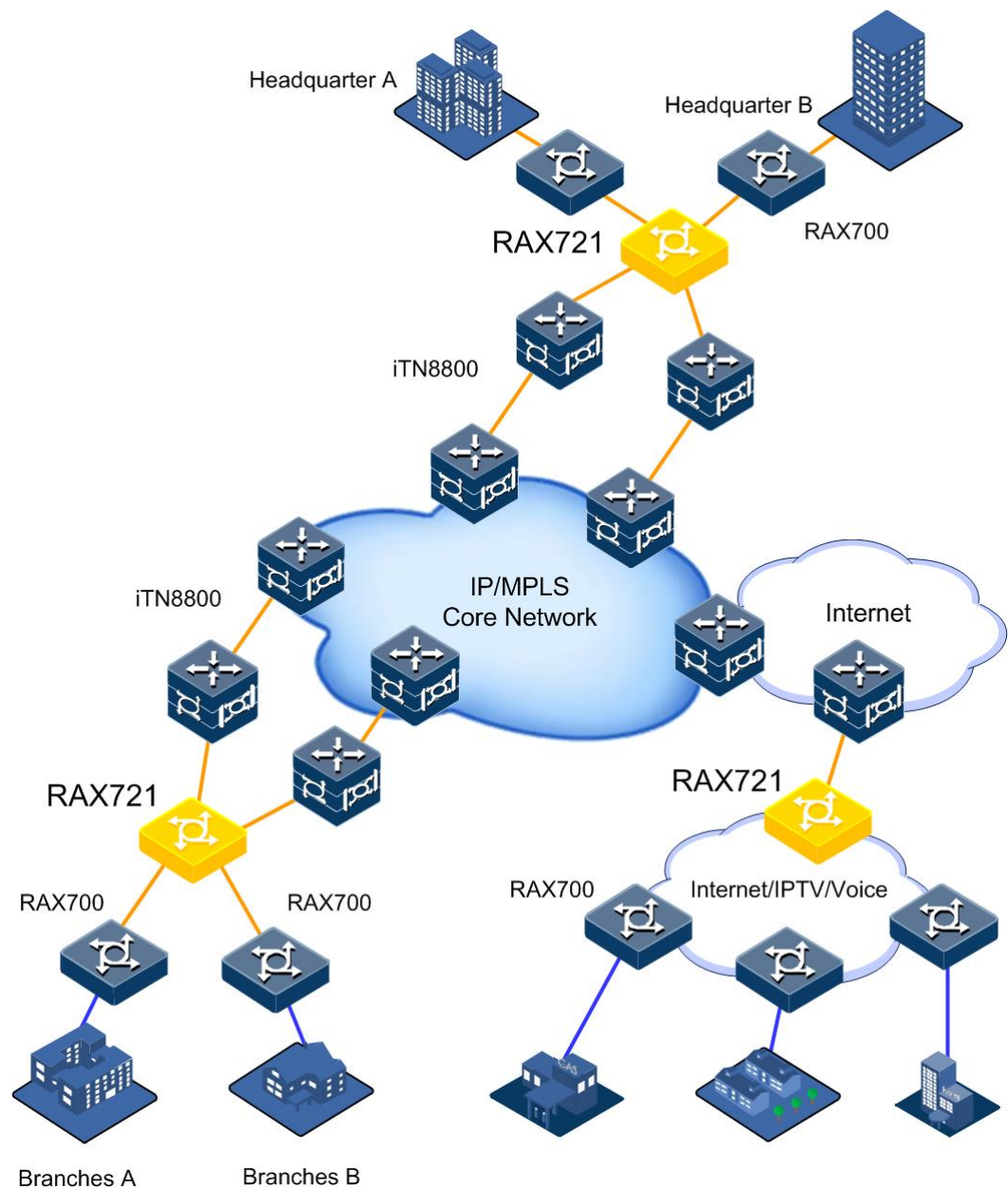

As shown in Figure 1-1, in a MAN access scenario, the RAX721-T-XF, as a pre-aggregation device, is connected downstream to the edge network RAX700, providing Layer 2 Ethernet private line and private network service solutions. The RAX721-T-XF also supports Layer 3 routing, MPLS network, and multicast switching, provides comprehensive access, such as IPTV, Internet access, and voice, delivering safe and reliable integration solutions.

Figure 1-1 RAX721-T-XF networking



1.3 Ordering information

1.3.1 Ordering information

Model	Version	Name	Description
RAX721-T-XF-AC/S	C	Intelligent transmission network device	<p>1U desktop device, four 10/1 Gbit/s SFP+ interfaces, twenty-four 10 Gbit/s, 1 Gbit/s, or 100 Mbit/s SFP+ electrical interfaces, Console and SNMP interfaces, single AC (100–240 V) power supply</p> <p> Note The device with a single power supply should be equipped with a fan card FANS310.</p>
RAX721-T-XF-AC/D	C	Intelligent transmission network device	<p>1U desktop device, four 10/1 Gbit/s SFP+ interfaces, twenty-four 10 Gbit/s, 1 Gbit/s, or 100 Mbit/s SFP+ electrical interfaces, Console and SNMP interfaces, dual AC (100–240 V) power supplies</p>
RAX721-T-XF-DC/S	C	Intelligent transmission network device	<p>1U desktop device, four 10/1 Gbit/s SFP+ interfaces, twenty-four 10 Gbit/s, 1 Gbit/s, or 100 Mbit/s SFP+ electrical interfaces, Console and SNMP interfaces, single DC (-48 V) power supply</p> <p> Note The device with a single power supply should be equipped with a fan card FANS310.</p>
RAX721-T-XF--DC/D	C	Intelligent transmission network device	<p>1U desktop device, four 10/1 Gbit/s SFP+ interfaces, twenty-four 10 Gbit/s, 1 Gbit/s, or 100 Mbit/s SFP+ electrical interfaces, Console and SNMP interfaces, dual DC (-48 V) power supplies</p>
RAX721-T-XF-AC_DC	C	Intelligent transmission network device	<p>1U desktop device, four 10/1 Gbit/s SFP+ interfaces, twenty-four 10 Gbit/s, 1 Gbit/s, or 100 Mbit/s SFP+ electrical interfaces, Console and SNMP interfaces, one AC (100–240 V) and one DC (-48 V) power supplies</p>

2 System structure

This chapter describes the system structure of the RAX721-T-XF, including the following sections:

- Hardware structure
- Software structure

2.1 Hardware structure

The entire structure of the RAX721-T-XF includes the appearance, interface type, LEDs, and power supply.

2.1.1 Appearance

The RAX721-T-XF adopts a compact chassis structure. All service interfaces and management interfaces are located on the front of the device, and the power interface is on the back.

Figure 2-1 shows the front appearance of the RAX721-T-XF. Figure 2-2, Figure 2-3, Figure 2-4, Figure 2-5, and Figure 2-6 show the rear appearance of the RAX721-T-XF.

Figure 2-1 Front appearance of the RAX721-T-XF

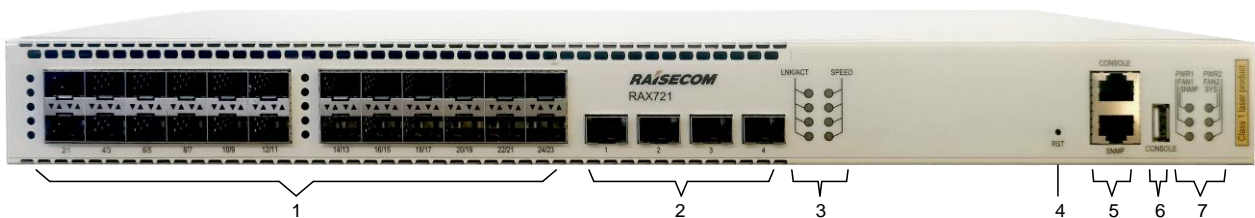

Figure 2-2 Rear appearance of the RAX721-T-XF dual AC model

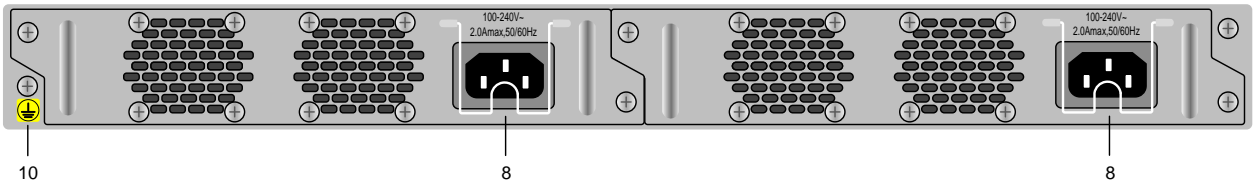

Figure 2-3 Rear appearance of the RAX721-T-XF dual DC model

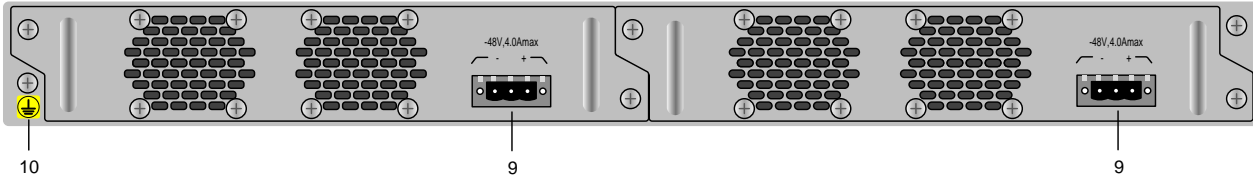

Figure 2-4 Rear appearance of the RAX721-T-XF AC + DC model

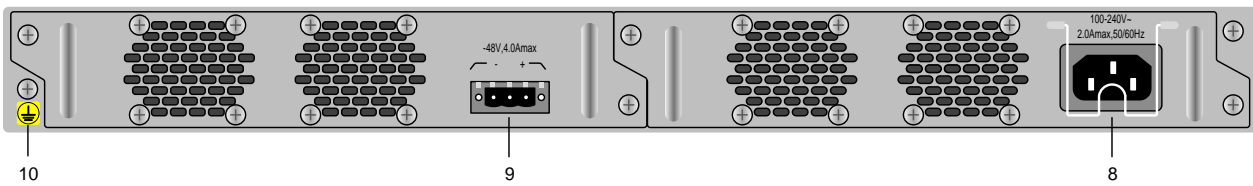

Figure 2-5 Rear appearance of the RAX721-T-XF single AC+FANS310 model

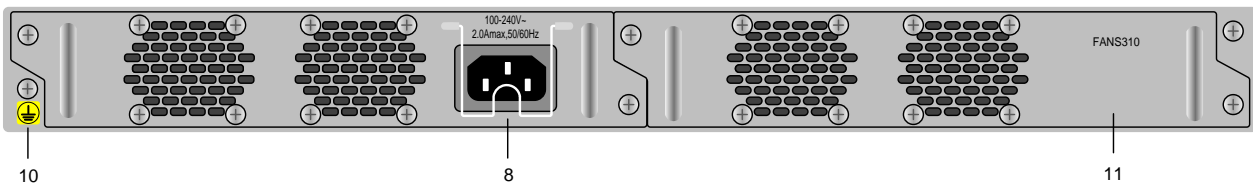

Figure 2-6 Rear appearance of the RAX721-T-XF single DC+FANS310 model

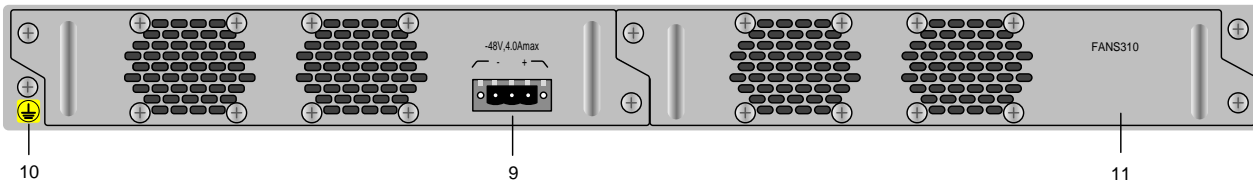



Table 2-1 lists the appearance descriptions.

Table 2-1 Appearance description

No.	Print	Description
1	1–24	<p>Service downlink interface (SFP+) and service downlink interface LED</p> <ul style="list-style-type: none"> ▼ : LINK/ACT LED ▲ : SPEED LED <p> Note</p> <p>The service downlink interface is compatible with 10Gbit/s, 1 Gbit/s, and 100 Mbit/s.</p>
2	1–4	<p>Service uplink interface (SFP+)</p> <ul style="list-style-type: none"> • Left: LINK/ACT LED • Right: SPEED LED <p> Note</p> <p>The service downlink interface is compatible with 10 Gbit/s, 1 Gbit/s, and 100 Mbit/s. When you use the speed command to configure the rate of one uplink interface, the rate of other three interfaces will be changed accordingly.</p>
3	LINK/ACT, SPEED	Service uplink interface LED
4	RESET	Reset button
5	SNMP	SNMP interface (RJ45)
5	CONSOLE	Console interface (RJ45)
6	CONSOLE	Console interface (USB)
7	<ul style="list-style-type: none"> • PWR1, PWR2 • FAN1, FAN2 • SNMP, SYS 	<ul style="list-style-type: none"> • Power 1 and power 2 LEDs • Fan 1 and fan 2 LEDs • SNMP interface LED and SYS LED
8	100-240V~ 2Amax,50/60Hz	AC power supply
9	48V,4Amax	DC power supply
10	–	Ground terminal
11	FANS310	Single fan card, which is needed when there is only one power supply

2.1.2 Interface types

The external interfaces on the RAX721-T-XF include the service interfaces and management interfaces.

Service interfaces

Table 2-2 lists the service interfaces on the RAX721-T-XF.

Table 2-2 Service interfaces on the RAX721-T-XF

Print	Interface type	Description	Quantity
1-4	Service uplink interface (SFP+)	<p>Service uplink interface (SFP+), with the following SFP optical modules available:</p> <ul style="list-style-type: none"> • 10GBASE-SR • 10GBASE-LR • 10GBASE-ER • 10GBASE-ZR • 1000BASE-X <p> Note</p> <p>When you use the speed command to configure the rate of one uplink interface, the rate of other three interfaces will be changed accordingly.</p>	4
1-24	Service downlink interface (SFP+/SFP)	<p>Service downlink interface (SFP+/SFP)</p> <p>Available SFP optical module:</p> <ul style="list-style-type: none"> • 10GBASE-SR • 10GBASE-LR • 10GBASE-ER • 10GBASE-ZR • 1000BASE-X • 100BASE-FX <p>Available SFP electrical module:</p> <ul style="list-style-type: none"> • 1000BASE-T • 100BASE-T 	24

Management interfaces

Table 2-3 lists the management interfaces on the RAX721-T-XF.

Table 2-3 Management interfaces on the RAX721-T-XF

Print	Interface type	Description	Quantity
USB	Console interface (RJ45)	<p>Auxiliary management interface. You can use the PC terminal software (such as Hyper Terminal in Windows) to perform initial configuration and management of the device through this interface.</p> <p> Note</p> <p>The RJ45 Console interface and USB Console interface cannot work concurrently. The priority of the USB Console interface is higher than that of the RJ45 Console interface. In other words, when both are connected with cables, the USB Console interface prevails.</p>	1
CONSOLE	Console interface (USB)	Auxiliary management interface. You can use the PC terminal software (such as Hyper Terminal in Windows) to perform initial configuration and management of the device through this interface.	1
SNMP	SNMP interface (RJ45)	<p>Out-of-band network management interface</p> <p>The device is connected to the network management server through this interface.</p>	1

2.1.3 LEDs

Table 2-4 lists LEDs on the RAX721-T-XF.

Table 2-4 LEDs on the RAX721-T-XF

Interface type	LED	Status	Description
–	PWR1/PWR2/	Green	<p>Power LED</p> <ul style="list-style-type: none"> • On: the power supply is normal. • Off: there is no power supply or the power supply is abnormal.
–	SYS	Green	<p>System working status LED</p> <ul style="list-style-type: none"> • On or Off: the system is working improperly. • Blinking (1 Hz): the system is working properly. • Fast blinking (4 Hz): the configuration file is being loaded or automatic deployment fails.

Interface type	LED	Status	Description
–	FAN1/FAN2	Green	Fan working status LED <ul style="list-style-type: none"> • On: the fan is working properly. • Blinking: the fan is not working properly. • Off: the fan module is not installed.
SNMP interface	SNMP	Green	Interface working status LED <ul style="list-style-type: none"> • On: the SNMP interface is working properly. • Blinking: the SNMP interface is receiving or sending data. • Off: the SNMP interface is not connected or connected abnormally.
Service uplink interface	LINK/ACT	Green	Service uplink interface working status LED <ul style="list-style-type: none"> • On: the link is properly connected. • Blinking: the link is sending or receiving data. • Off: the link is not connected or not working.
	SPEED	Green	Service uplink interface working rate LED <ul style="list-style-type: none"> • On: the SFP+ optical interface is working at 10 Gbit/s. • Off: the SFP+ optical interface is working at 1000 Mbit/s or not working
Service downlink interface	LINK/ACT	Green	Service downlink interface working status LED <ul style="list-style-type: none"> • On: the link is connected properly. • Blinking: the link is sending and receiving data. • Off: the link is not connected or not working.
	SPEED	Green	Service downlink interface working rate LED <ul style="list-style-type: none"> • On: the optical interface is working at 10 Gbit/s. • Off: the optical interface is working at 1000/100 Mbit/s or not working.

2.1.4 Power supplies

The RAX721-T-XF supports the AC and DC power supplies.

Table 2-5 lists the input power interfaces on the RAX721-T-XF.

Table 2-5 Input power interfaces on the RAX721-T-XF

Power type	Voltage range	Interface type
AC input voltage	Rated voltage: 220 V	C13 connector interface
	Voltage range: 100–240 V	
DC input voltage	Rated voltage: -48 V	3-PIN DC interface card
	Voltage range: -36 to -72 V	

2.2 Software structure

The Raisecom Operating System (ROS) platform is the core of the product software architecture of Raisecom. It is responsible for managing the underlying hardware architecture of the entire product, while providing unified operation to the upper-layer software system applications. The platform is reliable, real-time, self-healing, and maintainable.

Based on the ROS platform, the RAX721-T-XF provides the service and function module, system management module, network management module, and RCView.

Figure 2-7 lists the software structure of the RAX721-T-XF.

Figure 2-7 Software structure of the RAX721-T-XF

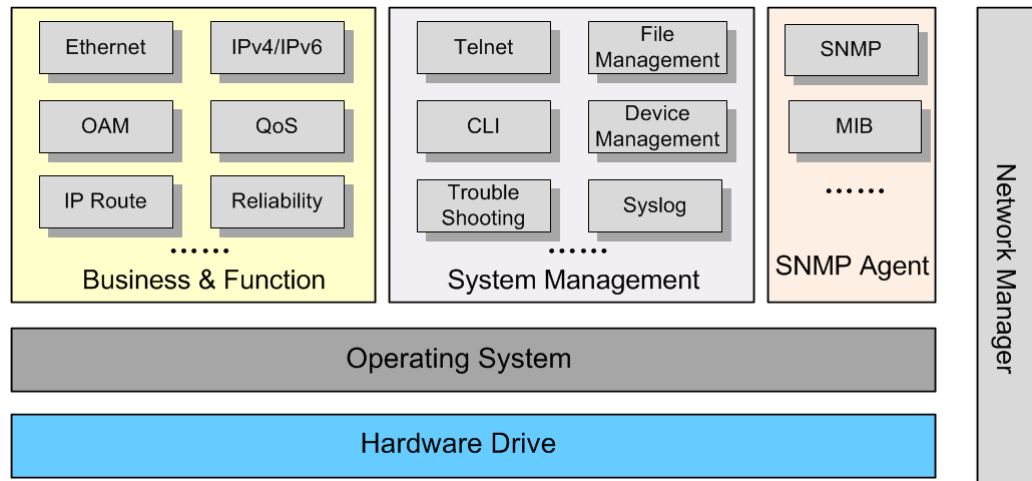

The functions provided by each module of the RAX721-T-XF software are as below:

- Services and functions: provide multiple services and functions, including Ethernet, VLAN, IPv4/IPv6, IP routing, MPLS, ACL, QoS, OAM, and network reliability.
- System management: provide file management, remote login (Telnet and SSHv2), CLI, alarm management and system log, to facilitate the management and maintenance of the device.
- Network management module (Agent): convert commands or information requests from the NMS into device-specific operation instructions, complete the NMS's instructions, and actively report equipment events to the NMS.
- Raisecom network management system: it is responsible for issuing management operation instructions and receives management information from the Agent to implement the centralized configurations of network elements, fault detection, topology management, alarm management, and so on.

3 Technical specifications

This chapter introduces technical specifications of the RAX721-T-XF, including the following sections:

- Overall specifications
- Interface specifications
- Laser safety class
- Reliability specifications
- EMC
- Safety standards
- Environmental requirements

3.1 Overall specifications

Table 3-1 lists overall specifications of the RAX721-T-XF (A).

Table 3-1 Overall specifications of the RAX721-T-XF (A)

Parameter		Description
Dimensions (mm)		440 (Width) × 360 (Depth) × 44 (Height)
Power consumption (W)		< 100
Weight (kg)		< 64.22
DC input	Rated voltage (V)	-48
	Voltage range (V)	-36 to -72
AC input	Rated voltage (V)	220
	Voltage range (V)	100–240 (50/60 Hz)
Operating temperature (altitude: 0–1800 m)		-5 to +55 °C
Operating humidity		10%–95% RH (non-condensing)

Parameter		Description
Lightning protection level (kV)	AC power (kV)	<ul style="list-style-type: none"> Differential mode: ± 6 Common mode: ± 6
	DC power (kV)	<ul style="list-style-type: none"> Differential mode: ± 2 Common mode: ± 4
	Ethernet interface (kV)	Common mode (indoor): ± 1
Power input	AC power supply	100–240 VAC, 2 A, 50/60 Hz
	One AC power supply + one DC power supply	-48 V, 4 A; 100–240 VAC, 2 A, 50/60 Hz
	DC power supply	-48 V, 4 A



Note

At an altitude of 1800 m to 5000 m, the maximum operating temperature of the RAX721-T-XF reduces by 1°C for every 220 m increase in altitude.

3.2 Interface specifications

3.2.1 10 Gbit/s optical interfaces

Table 3-2 lists technical specifications of the 10 Gbit/s optical interfaces.

Table 3-2 Technical specifications of the 10 Gbit/s optical interfaces

Parameter	Description
Interface type	SFP+
Technical specifications of optical interfaces	Decided by the selected SFP+ optical module
Type of SFP+ optical module	<ul style="list-style-type: none"> 10Gbase-SR (0.3 multi-mode) 10Gbase-LR (10 km) 10Gbase-ER (40 km) 10Gbase-ZR (80 km)
Transmission rate	10.3125 Gbit/s
Operating mode	Full duplex mode
Maximum data frame length	13 kB
Standard	IEEE802.3ae-compliant

3.2.2 1000 Mbit/s optical interfaces

Table 3-3 lists technical specifications of the 1000 Mbit/s optical interfaces.

Table 3-3 Technical specifications of the 1000 Mbit/s optical interfaces

Parameter	Description
Interface type	SFP
Technical specifications of optical interfaces	Decided by the selected SFP optical module
Type of the SFP optical module	<ul style="list-style-type: none"> • 1000base-X • 100base-FX
Transmission rate	<ul style="list-style-type: none"> • 1000Base-SX, 1000Base-LX, and 1000Base-ZX: 1.25 Gbit/s • 100Base-FX: 100 Mbit/s
Operating mode	Full duplex mode
Maximum data frame length	13 Kbytes
Standard	IEEE802.3z and IEEE802.3u-compliant

3.2.3 SNMP interfaces

Table 3-4 lists technical specifications of the SNMP interfaces.

Table 3-4 Technical specifications of the SNMP interfaces

Parameter	Description
Connector type	RJ45
Interface rate	10/100/1000 Mbit/s auto-negotiation
Wiring	Auto-MDI/MDIX
Standard	IEEE 802.3-compliant

3.2.4 Console interface

USB Console interface

Table 3-5 lists technical specifications of the USB Console interface.

Table 3-5 Technical specifications of the USB Console interface

Parameter	Description
Connector type	USB

Parameter	Description
Operating mode	Half duplex
Electrical feature	USB
Baud rate	9600 baud
Cable specifications	4 cores

Table 3-6 lists technical specifications of the RJ45 Console interface.

Table 3-6 Technical specifications of the RJ45 Console interface

Parameter	Description
Connector type	RJ45
Operating mode	Duplex UART
Electrical feature	RS-232
Baud rate	9600 baud
Cable specifications	8 cores

3.3 Laser safety class

According to the output optical power of the laser, the safety level of the RAX721-T-XF laser is Class 1.

When the laser safety level is Class 1, the maximum power output of the optical interface is less than 10 dBm (10 mW).



The laser beam in the optical fiber may burn your eyes. During installation and maintenance, do not look directly at the end face of the optical fiber.

3.4 Reliability specifications

Table 3-7 lists reliability specifications of the RAX721-T-XF.

Table 3-7 Reliability specifications of the RAX721-T-XF

Parameter	Description
System availability	99.999%, with the downtime less than 5 minutes per year

Parameter	Description
Average annual repair rate	< 0.2%
MTTR	< 2 hours

3.5 EMC

The RAX721-T-XF is designed according to the recommendations of the ETS 300386 series and ETS 300127 formulated by the European Telecommunications Standards Institute (ETSI), and has passed Electromagnetic Compatibility (EMC) tests.

3.6 Safety standards

The RAX721-T-XF complies with the following safety standards:

- EN 62368-1
- UL 62368-1

3.7 Environmental requirements

The RAX721-T-XF is applicable to the following scenarios:

- Telecommunication room
- Small telecommunication center or corridor

The environment should meet the following requirements:

- GF 014-1995 telecommunication room environmental requirements
- ETSI EN 300 019

3.7.1 Storage environment

Climatic environment

Table 3-8 lists climatic environmental requirements for storage.

Table 3-8 Climatic environmental requirements for storage

Parameter	Description
Air pressure (kPa)	86–106
Storage temperature (°C)	-40 to +70
Operating humidity	10%–95% RH (non-condensing)

Parameter	Description
Solar radiation (W/m ²)	≤ 1120
Heat radiation (W/m ²)	≤ 600
Wind speed (m/s)	≤ 20

Waterproof requirements

Storage requirements for customer field devices: indoor storage should be generally ensured.

Ensure that there is no impounded water on the ground and avoid liquid leakage into the device. Put the RAX721-T-XF away from the automatic fire-fighting facility, heaters, and so on.

If the RAX721-T-XF is installed outdoor, the following conditions should be met:

- Ensure that the packing case is intact.
- Take measures to prevent rain from entering the packing case.
- Ensure that there is no impounded water on the ground. No water is allowed to enter the packing case.
- Ensure that the packing case is not exposed to direct sunlight.

Biotic environment

- Keep the environment clean and dry to avoid reproduction of microbes, such as fungi and molds.
- Be away from the rodent, such as rats.

Air cleanliness

There should not be any explosive, electro-conductive, magneto-conductive, or corrosive substance.

Table 3-9 lists concentration requirements on the mechanical active substance for storage.

Table 3-9 Concentration requirements on the mechanical active substance for storage

Mechanical active substance	Concentration
Suspending dust (mg/m ³)	≤ 5.00
Droppable dust (mg/m ² h)	≤ 20.00
Grit (mg/m ³)	≤ 300

Table 3-10 lists concentration requirements on the chemical active substance for storage.

Table 3-10 Concentration requirements on the chemical active substance for storage

Chemical active substance	Concentration
SO ₂ (mg/m ³)	≤ 0.30
H ₂ S (mg/m ³)	≤ 0.10
NO ₂ (mg/m ³)	≤ 0.50
NH ₃ (mg/m ³)	≤ 1.00
Cl ₂ (mg/m ³)	≤ 0.10
HCl (mg/m ³)	≤ 0.10
HF (mg/m ³)	≤ 0.01
O ₃ (mg/m ³)	≤ 0.05

3.7.2 Transport environment

Climatic environment

Table 3-11 lists climatic environment requirements for transportation.

Table 3-11 Climatic environment requirements for transportation

Parameter	Description
Air pressure (kPa)	86–106
Temperature (°C)	-40 to +70
Temperature change rate (°C/min)	≤ 1
Operating humidity	10%–95% RH (non-condensing)
Solar radiation (W/m ²)	≤ 1120
Heat radiation (W/m ²)	≤ 600
Wind speed (m/s)	≤ 20

Waterproof requirements

During transportation, the following conditions should be met:

- Ensure that the packing case is intact.
- Take measurements to prevent rain from entering the packing case.
- Ensure that there is no impounded water in the vehicle.

Biotic environment

- Keep the environment clean and dry to avoid reproduction of microbes, such as fungi and molds.
- Be away from the rodent, such as rats.

Air cleanliness

There should not be any explosive, electro-conductive, magneto-conductive, or corrosive substance.

Table 3-12 lists concentration requirements on the mechanical active substance for transportation.

Table 3-12 Concentration requirements on the mechanical active substance for transportation

Mechanical active substance	Concentration
Suspending dust (mg/m ³)	No requirement
Droppable dust (mg/m ² h)	≤ 3.0
Grit (mg/m ³)	≤ 100

Table 3-13 lists concentration requirements on the chemical active substance during transportation.

Table 3-13 Concentration requirements on the chemical active substance during transportation

Chemical active substance	Concentration
SO ₂ (mg/m ³)	≤ 0.30
H ₂ S (mg/m ³)	≤ 0.10
NO ₂ (mg/m ³)	≤ 0.50
NH ₃ (mg/m ³)	≤ 1.00
Cl ₂ (mg/m ³)	≤ 0.10
HCl (mg/m ³)	≤ 0.10
HF (mg/m ³)	≤ 0.01
O ₃ (mg/m ³)	≤ 0.05

3.7.3 Operating environment

Climatic environment



Note

The temperature and humidity are measured 1.5 m above the ground and 0.4 m front of the device.

Table 3-14 lists environmental requirements for running the RAX721-T-XF.

Table 3-14 Environmental requirements for running the RAX721-T-XF

Parameter	Description
Altitude (m)	≤ 4000
Air pressure (kPa)	86–106
Operating temperature (°C)	-5 to 55
Operating humidity	10%–95% RH (non-condensing)
Temperature change rate (°C/min)	≤ 0.5
Solar radiation (W/m ²)	≤ 700
Heat radiation (W/m ²)	≤ 600
Wind speed (m/s)	≤ 5

Biotic environment

- Keep the environment clean and dry to avoid reproduction of microbes, such as fungi and molds.
- Be away from the rodent, such as rats.

Air cleanliness

There should not be any explosive, electro-conductive, magneto-conductive, or corrosive substance.

Table 3-15 lists concentration requirements on the mechanical active substance during operation.

Table 3-15 Concentration requirements on the mechanical active substance during operation

Mechanical active substance	Concentration
Dust grain (grain/m ³)	$\leq 3 \times 10^5$
Suspending dust (mg/m ³)	≤ 0.2

Mechanical active substance	Concentration
Droppable dust (mg/m ³ h)	≤ 15
Grit (mg/m ³)	≤ 100

Table 3-16 lists concentration requirements on the chemical active substance during operation.

Table 3-16 Concentration requirements on the chemical active substance during operation

Chemical active substance	Concentration
SO ₂ (mg/m ³)	≤ 0.30
H ₂ S (mg/m ³)	≤ 0.10
NH ₃ (mg/m ³)	≤ 3.00
Cl ₂ (mg/m ³)	≤ 0.10
HCl (mg/m ³)	≤ 0.10
HF (mg/m ³)	≤ 0.01
O ₃ (mg/m ³)	≤ 0.05

4 Appendix

This chapter includes the following sections:

- Cables
- Terms
- Acronyms and abbreviations

4.1 Cables



The RAX721-T-XF is delivered without these cables. Purchase them as required.

4.1.1 Fiber

Introduction

The RAX721-T-XF can use the Single-Mode Fiber (SMF) and the Multi-Mode Fiber (MMF).

Table 4-1 shows types of the commonly-used fiber connectors.

Table 4-1 Types of the commonly-used fiber connectors

Local connector	Remote connector	Cable type
LC/PC	LC/PC	2-mm SMF
		2-mm MMF
LC/PC	FC/PC	2-mm SMF
		2-mm MMF
LC/PC	SC/PC	2-mm SMF
		2-mm MMF



Select the type and length of the fiber connector properly according to the actual condition on site.

The RAX721-T-XF adopts the LC/PC fiber connector.

Appearance

Figure 4-1 shows the LC/PC fiber connector.

Figure 4-1 LC/PC fiber connector.

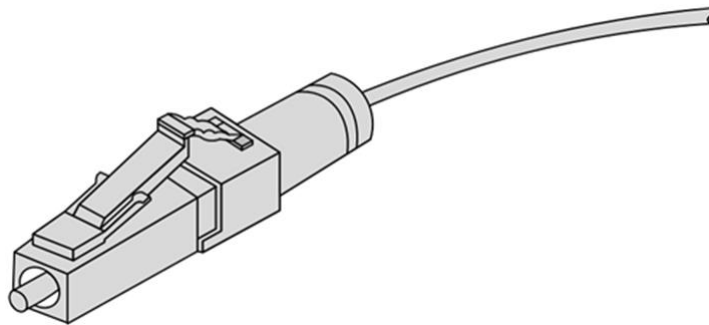

When connecting or removing the LC/PC fiber connector, align the connector with the optical interface, and do not rotate the fiber. Operate the fiber as below:

- Align the head of the fiber with the optical interface and insert the fiber into the interface gently.
- To remove the fiber, press the latch on the connector, push the fiber head inward slightly, and then pull the fiber out.

4.1.2 Ethernet cable

Introduction

For the RAX721-T-XF, the Ethernet cable is used as below:

- Connect the Ethernet electrical interfaces of the RAX721-T-XF to other devices.
- Connect the SNMP interfaces of the RAX721-T-XF to the NView NNM system.

For the RAX721-T-XF, the Ethernet interfaces is adaptive to straight-through and crossover modes. Therefore, both modes are applicable when you connect the Ethernet service interfaces.

Appearance

Figure 4-2 shows the Ethernet cable.

Figure 4-2 Ethernet cable

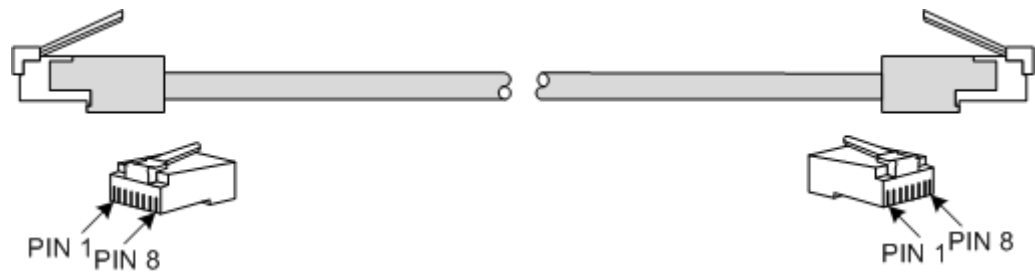

Technical specifications

The Ethernet cable is divided into two types: straight-through cable and crossover cable

- Straight-through cable: for connecting devices of different types, such as a PC and a switch, or a switch and a router
- Crossover cable: for connecting devices of the same type, such as a switch and a switch, a router and a router, a PC and a router (PC and router belong to the same type)

Table 4-2 lists the wiring of EIA/TIA568A and EIA/TIA568B standards.

Table 4-2 Wiring of EIA/TIA568A and EIA/TIA568B standards

Connector 1 (RJ45)	EIA/TIA 568A	Connector 2 (RJ45)	EIA/TIA 568B
PIN 1	White/Green	PIN 1	White/Orange
PIN 2	Green	PIN 2	Orange
PIN 3	White/Orange	PIN 3	White/Green
PIN 4	Blue	PIN 4	Blue
PIN 5	White/Blue	PIN 5	White/Blue
PIN 6	Orange	PIN 6	Green
PIN 7	White/Brown	PIN 7	White/Brown
PIN 8	Brown	PIN 8	Brown

Straight-through cable

Both two RJ45 connectors of the straight-through cable follow EIA/TIA568 B standard wiring, as shown in Figure 4-3.

Figure 4-3 Wiring of the straight-through cable

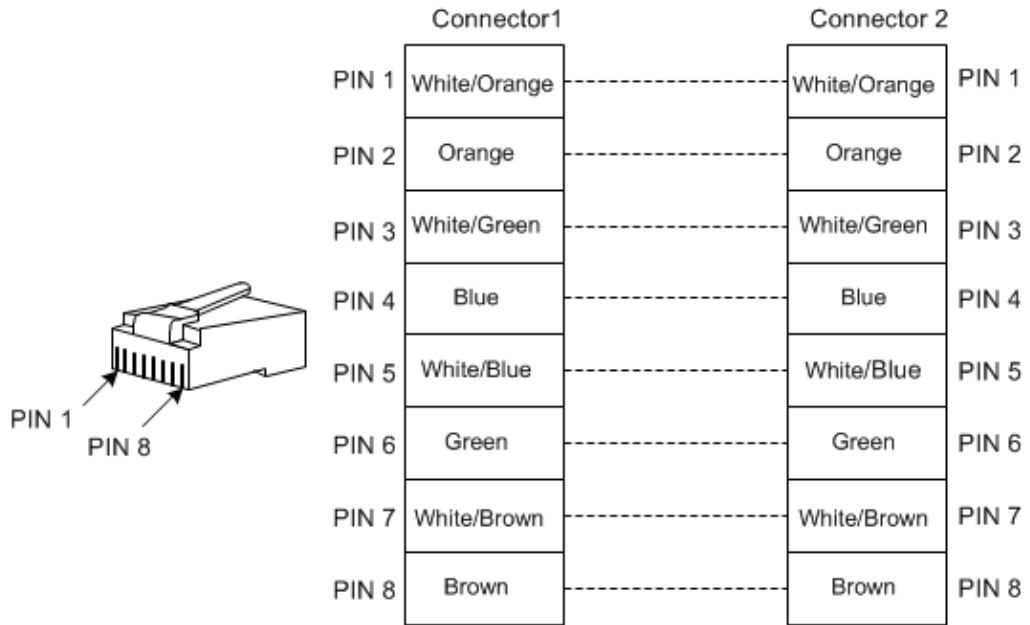

Crossover cable

The methods of making the wiring of the 100 Mbit/s and 1000 Mbit/s crossover cables are slightly different. The RJ45 connector at one end of the 100 Mbit/s crossover cable adopts the EIA/TIA 568A standard wiring while the other end adopts the EIA/TIA 568B standard.

Figure 4-4 shows the wiring of the 100 Mbit/s crossover cable.

Figure 4-4 Wiring of the 100 Mbit/s crossover cable

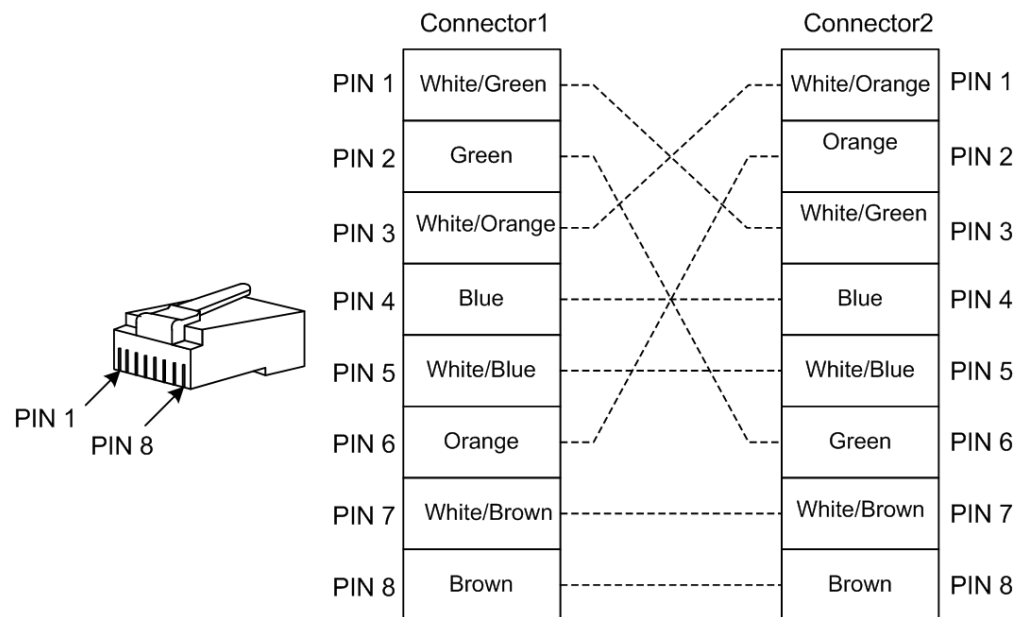

The 1000 Mbit/s crossover cable uses all 8 pins. The crossover is PIN 1 to PIN 3, PIN 2 to PIN 6, PIN 4 to PIN 7, and PIN 5 to PIN 8, as shown in Figure 4-5.

Figure 4-5 shows the wiring of the 1000 Mbit/s crossover cable.

Figure 4-5 Wiring of the 1000 Mbit/s crossover cable

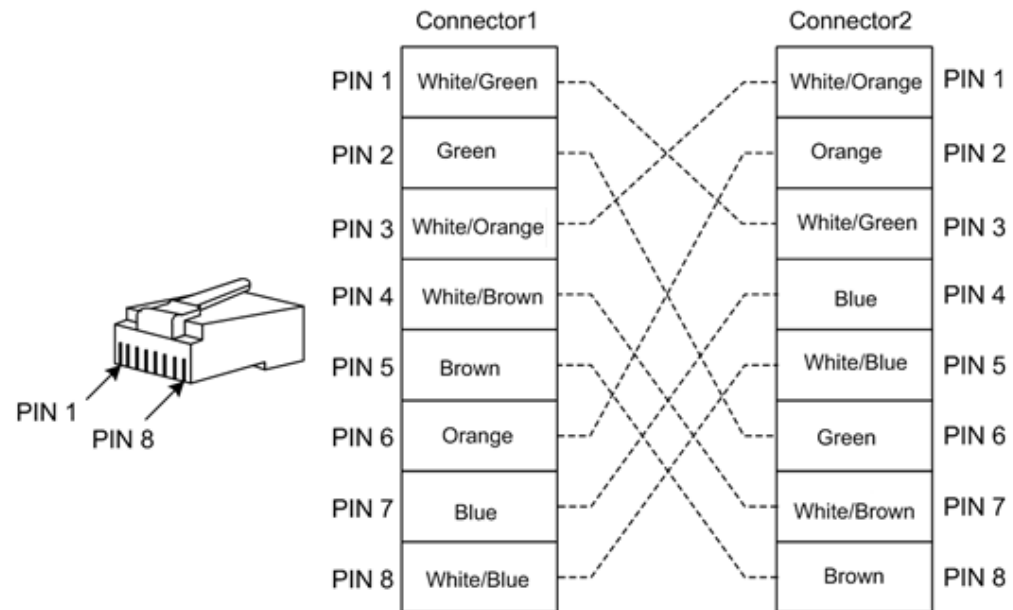

Raisecom can provide straight-through cables and 100 Mbit/s crossover cables. The two types of cable have different names. The straight-through cable is named CBL-ETH-RJ45/RJ45-D while the crossover cable is named CBL-ETH-RJ45/RJ45-X-D.

Table 4-3 lists technical specifications of the Ethernet cable.

Table 4-3 Technical specifications of the Ethernet cable

Parameter	Description
Cable color	Dark gray
Cable model	Cat 5 or better UTP (UTP-5/UTP-5e) or STP cable
Cable connector	RJ45 connector
Number of cores	8
Length	The letter D is the length, which can be customized. For example, if you require a 2-meter cable, you can name it CBL-ETH-RJ45/RJ45-2m.

4.1.3 USB configuration cable

Introduction

The configuration cable is used to connect the Console interface of the device and the RS-232 serial interface of the maintenance Console and transmit configuration data. The maintenance

Console implements local serial cable debugging and maintenance through the Console interface.

The connectors at two ends of the configuration cable are as below:

- USB: connected to the USB-type Console interface of the device
- USB: connected to the USB interface of the maintenance Console

Appearance

Figure 4-6 shows the appearance of the configuration cable.

Figure 4-6 Configuration cable



Wiring

Figure 4-7 shows the PINs and wiring of the cable-side terminal.

Figure 4-7 PINs and wiring

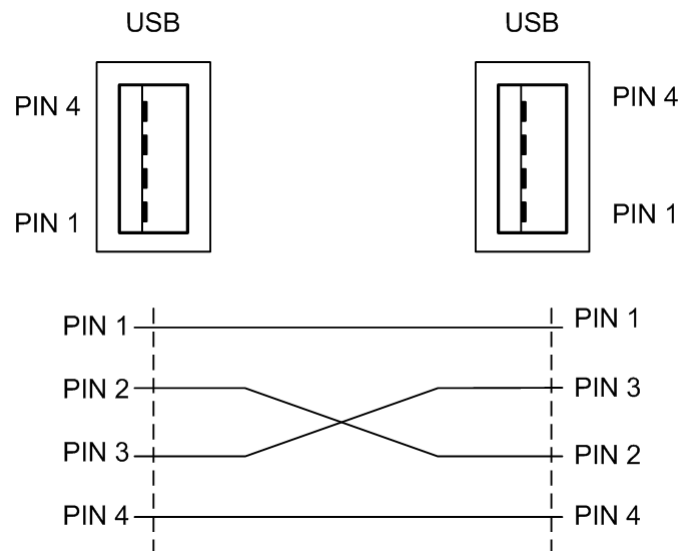

Technical specifications

Table 4-4 lists technical specifications of the configuration cable.

Table 4-4 Technical specifications of the configuration cable

Parameter	Description
Cable name	CBL-USB-USB-AM/USB-AM-1.5m/RoHS
Connector type	USB2.0 AM connector + USB2.0 AM connector

Parameter	Description
Cable model	UL2725
Length	1.5 m

4.1.4 RS232 configuration cable

Introduction

The configuration cable is used to connect the Console interface on the device to the RS-232 serial interface on the maintenance console, and it transmits configuration data signals. You can debug and maintain the device through the maintenance console.

The configuration cable is an 8-core unshielded cable, with connectors as below:

- RJ45 connector: connected to the Console interface on the device
- DB9 female connector: connected to the Console interface on the PC

Appearance

Figure 4-8 shows the configuration cable.

Figure 4-8 Configuration cable

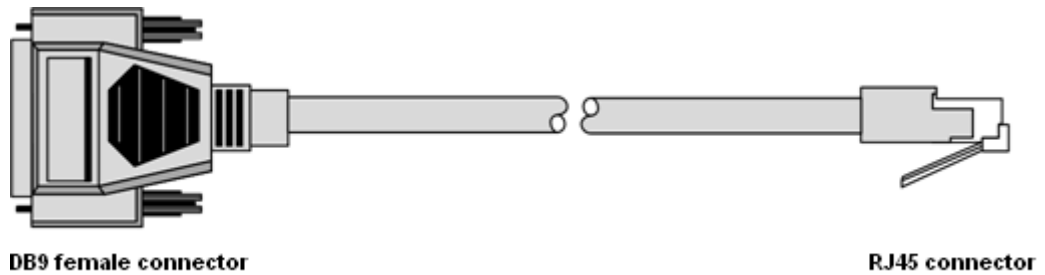

Wiring

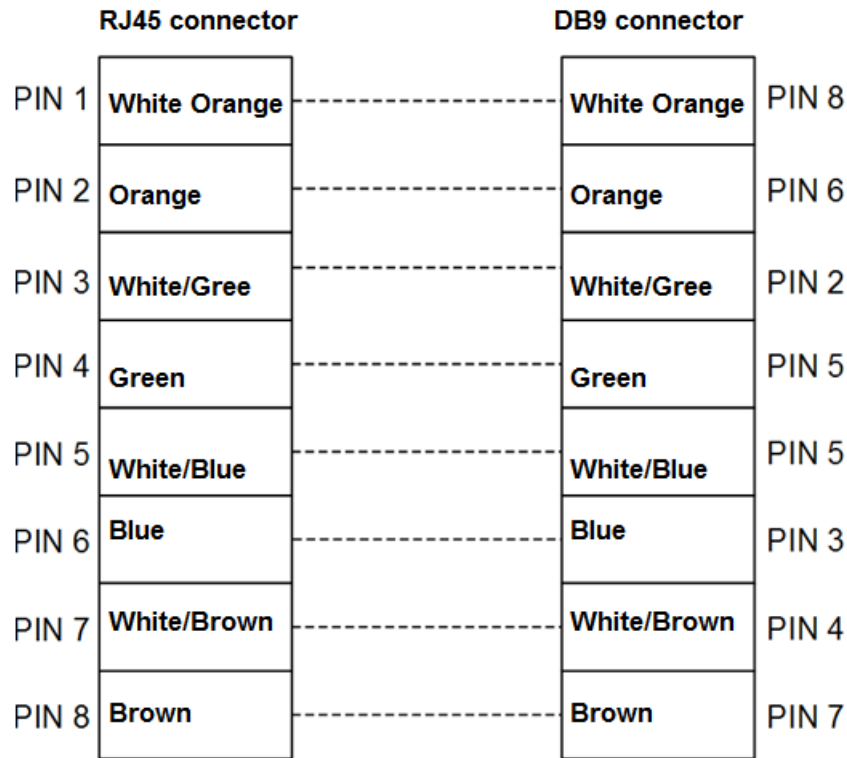

Technical specifications

Table 4-5 lists technical specifications of the configuration cable.

Table 4-5 Technical specifications of the configuration cable

Parameter	Description
Name	CBL-RS232-DB9F/RJ45-B-2m/RoHS
Type	Unshielded Cat 3 twisted pair cable
Connector	<ul style="list-style-type: none"> • RJ45 connector • DB9 female connector
Length	2 m

4.1.5 DC power cable

Introduction

The DC power cable transmits -48 VDC power from the DC power distribution device to the DC terminal block on the front panel of the device to power the entire device.

Appearance

The DC power cable is composed of the power connector and coaxial cable, as shown in Figure 4-9.

Figure 4-9 DC power cable

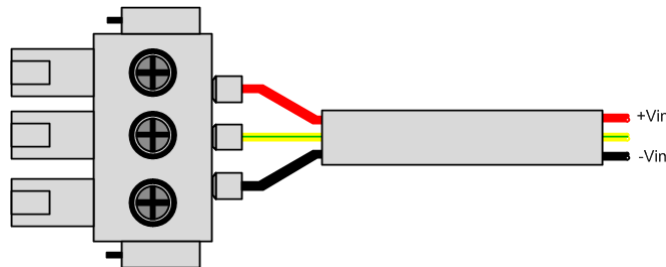

Technical specifications

Table 4-6 lists technical specifications of the DC power cable.

Table 4-6 Technical specifications of the DC power cable

Parameter	Description
Name	POL-DC-unstripped/stripped-1.0 mm ² -1.5m/RoHS
DC connector	5.08-3Pin-head/RoHS
Length	1.5 m

4.1.6 AC power cable

Introduction

The AC power cable transmits 220 VAC power from the AC power distribution equipment to the RAX721-T-XF cable terminal block to supply power to the entire device. The AC power cable used by the RAX721-T-XF varies according to the power cable standard in the region, as shown in Figure 4-10.

Figure 4-10 AC power cable

Regional standard	Description
European	POL-AC-European standard 3-pin/C13 connector-0.75mm ² -1.5m/RoHS
American	POL-AC-American standard-3-pin/C13 connector-18AWG-1.5m/RoHS

 **Note**

Raisecom can provide the AC power cable which meets Brazil requirements. If required, contact Raisecom technical support engineers.

Appearance

The AC power cable which meets European standard is composed of the European French-mode 3-pin plug and 3-pin C13 connector, as shown in Figure 4-11.

Figure 4-11 European AC power cable

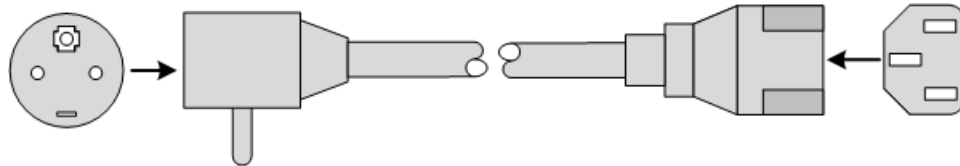

The AC power cable which meets American standard is composed of the American 3-pin plug and 3-pin C13 connector, as shown in Figure 4-12.

Figure 4-12 American AC power cable



Technical specifications

Table 4-7 lists the technical specifications of the European AC power cable.

Table 4-7 Technical specifications of the European AC power cable

Parameter		Description
Name		French C13 connector-10A/250V-1.5m/RoHS
Color	Outer	Black (PVC insulating layer)
	Inner	Blue (N) and brown (L)
Connector type 1		C13 connector
Connector type 2		European French 3-pin connector
Wire gauge of inner conductor		18 AWG
Cross-sectional area of inner conductor		$3 \times 0.75 \text{ mm}^2$
Length		1.5 m

Table 4-8 lists technical specifications of the American AC power cable.

Table 4-8 Technical specifications of the American AC power cable

Parameter		Description
Name		American 3-pin-10A/250V-1.5m/RoHS
Color	Outer	Black (PVC insulating layer)
	Inner	Blue (N) and brown (L)
Connector type 1		C13 connector
Connector type 2		American 3-pin connector NMEA5-15
Wire gauge of inner conductor		18 AWG
Cross-sectional area of inner conductor		$3 \times 0.75 \text{ mm}^2$
Length		1.5 m

4.1.7 Ground cable



Warning

Connecting the ground cable properly is an important guarantee for lightning protection, shock proof, and anti-interference. When installing and using the device, ensure that the ground cable is properly connected; otherwise, personnel injury or device damage may occur.



Note

- The device is delivered with an OT terminal instead of a ground cable. If needed, you can prepare one by yourself or you can make one on site according to the technical specifications.
- The ground cable shall not be longer than 30 m and better be as short as possible. If the ground cable is longer than 30 m, you need to use a ground bar for connection.

Introduction

The ground cable is used to connect the RAX721-T-XF to the ground.

The device can be grounded by connecting the ground terminal to the ground cable or by grounding the power cable. The RAX721-T-XF belongs to Class A devices.

Appearance

The ground cable is composed of ground lugs and the coaxial cable. The ground lug is usually an OT non-insulated terminal. The coaxial cable is a yellow/green copper soft flame-retardant conducting wire. Figure 4-13 and Figure 4-14 show the ground cable and OT terminal.

Figure 4-13 Ground cable

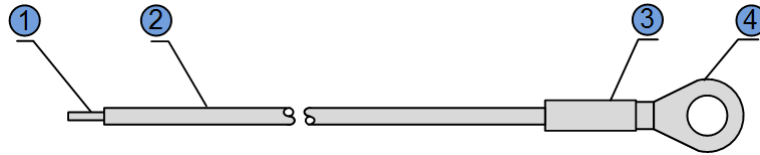

1	Stripped end (connected to the OT terminal or ground bar)	2	Conducting wire
3	Insulating sheath	4	OT terminal

Figure 4-14 OT terminal

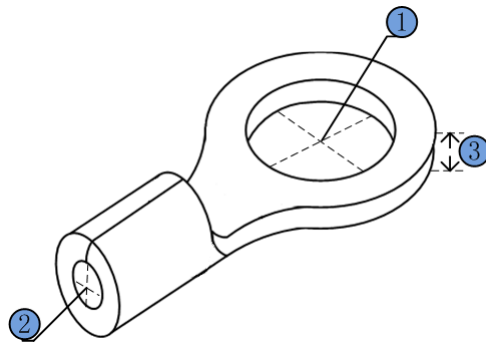

1	Inner diameter of soldering lug	2	Inner diameter of sheath	3	Thickness of soldering terminal
---	---------------------------------	---	--------------------------	---	---------------------------------

Technical specifications

Table 4-9 lists technical specifications of the ground cable.

Table 4-9 Technical specifications of the ground cable

Parameter	Description
Model	POL-ground cable-OT1.5-4/stripped-16AWG-D/RoHS
Standard	Comply with UR standard and meet RoHS requirements.
Length	1m or customized The letter D is the length, which can be customized.

Table 4-10 lists technical specifications of the OT terminal.

Table 4-10 Technical specifications of the OT terminal

Parameter	Description
Model	Protective grounding round-pressed terminal (M4)/RoHS
Technical specifications	4.3 soldering lug <ul style="list-style-type: none"> • Inner diameter of soldering lug: 4 mm • Outer diameter of soldering lug: ≤ 8 mm • Inner diameter of sheath: 2.1 mm • Thickness of soldering lug: ≥ 0.6 mm
Cross-sectional area of the conducting wire	16–15 AWG (1.2–1.5 mm ²)

4.2 Terms

Numerics

100BASE-T	A FE standard for twisted-pair cables. Fast Ethernet refers to any network that supports transmission rate of 100Mbps/s. The Fast Ethernet is 10 times faster than 10BaseT, and inherits frame format, MAC addressing scheme, MTU, and so on. Fast Ethernet is extended from the IEEE802.3 standard, and it uses the following three types of transmission media: 100BASE-T4: 4 pairs of phone twisted-pair cables 100BASE-TX: 2 pairs of data twisted-pair cables 100BASE-FX: 2-core optical fibers.
100BASE-TX	100BASE-TX makes use of two pairs of twisted pair cable. One pair is used for transmission and the other pair is used for reception. Both the STP cable and Cat 5 UTP cable are allowed.

A

Access Control List (ACL)	A series of ordered rules composed of permit deny sentences. These rules are based on the source MAC address, destination MAC address, source IP address, destination IP address, interface ID, etc. The device decides to receive or refuse the packets based on these rules.
Automatic Protection Switching (APS)	APS is used to monitor transport lines in real time and automatically analyze alarms to discover faults. When a critical fault occurs, through APS, services on the working line can be automatically switched to the protection line, thus the communication is recovered in a short period.

Auto-negotiation The interface automatically chooses the rate and duplex mode according to the result of negotiation. The auto-negotiation process is: the interface adapts its rate and duplex mode to the highest performance according to the peer interface, that is, both ends of the link adopt the highest rate and duplex mode they both support after auto-negotiation.

B

Baud rate Times of signal changes every second on a transmission link. In general, there are only two types of signal status, so the baud rate is the number of bits transmitted every second. Since lower-layer transmission will occupy some bandwidth, so user data are not necessarily transmitted according to the rated baud rate.

C

Clock synchronism The Synchronous Digital Hierarchy (SDH) network adopts the hierarchical master-slave synchronization mode. Namely, a Primary Reference Clock (PRC) controls clock synchronization on the entire network through synchronization links. A series of hierarchical clocks are used and clocks at each hierarchy are synchronized to the clocks at the upper or same hierarchy.

Connectivity Fault Management (CFM) CFM, defined by ITU-Y.1731 and IEEE802.1ag, is an end-to-end service-level Ethernet OAM technology. This function is used to actively diagnose faults for Ethernet Virtual Connection (EVC), provide cost-effective network maintenance solutions, and improve network maintenance.

D

Dynamic Host Configuration Protocol (DHCP) A technology used for assigning IP address dynamically. It can automatically assign IP addresses for all clients in the network to reduce workload of the administrator. In addition, it can realize centralized management of IP addresses.

E

Electro Magnetic Compatibility (EMC) EMC refers to the capability of a device or sub-system to work properly in an electromagnetic environment without causing unbearable electromagnetic disturbance on other devices or sub-systems. It is an important indicator of system reliability.

Ethernet It is founded by Xerox Corporation and defined by DEC, Intel, and Xerox. Ethernet is the most widely used LAN. Its rates include 10 Mbit/s, 100 Mbit/s, and 1000 Mbit/s. Ethernet adopts CSMA/CD mechanism and complies with IEEE 802.3 standard.

Ethernet in the First Mile (EFM)	Complying with IEEE 802.3ah protocol, EFM is a link-level Ethernet OAM technology. It provides the link connectivity detection, link fault monitoring, and remote fault notification, etc. for a link between two directly-connected devices. EFM is mainly used for the Ethernet link on edges of the network accessed by users.
Ethernet Linear Protection Switching (ELPS)	It is an APS protocol, based on ITU-T G.8031 standard, used to protect the Ethernet link. It is an end-to-end protection technology, including two line protection modes: linear 1:1 protection switching and linear 1+1 protection switching.
Ethernet Ring Protection Switching (ERPS)	It is an APS protocol based on ITU-T G.8032 standard, which is a link-layer protocol specially used for the Ethernet ring. In normal conditions, it can avoid broadcast storm caused by the data loop on the Ethernet ring. When the link or device on the Ethernet ring fails, services can be quickly switched to the backup line to enable services to be recovered in time.
Extinction ratio	The extinction ratio refers to the smallest ratio of A and B in complete modulation under the worst reflection conditions, that is $ER=10\lg(A/B)$. Wherein, A refers to the average Tx optical power at high voltage level and B refers to that at low voltage level.
F	
Fiber	Filamentous optical waveguide composed of electrical materials, used to conduct electromagnetic energy in the form of optical wave.
Frame	It is a data transmission unit, composed of several parts, each of which has different functions.
Full duplex	In a communication link, both parties can receive and send data concurrently.
G	
Grounding cable	The cable to connect the device to ground, usually a yellow/green coaxial cable. Connecting the grounding cable properly is an important guarantee to lightning protection, anti-electric shock, and anti-interference.
H	
Half duplex	In a communication link, both parties can receive or send data at a time.
L	

Light Amplification by Stimulated Emission of Radiation (LASER)	A laser is a device that emits light through a process of optical amplification based on the stimulated emission of electromagnetic radiation.
Link Aggregation	With link aggregation, multiple physical Ethernet interfaces are combined to form a logical aggregation group. Multiple physical links in one aggregation group are taken as a logical link. Link aggregation helps share traffic among member interfaces in an aggregation group. In addition to effectively improving the reliability on links between devices, link aggregation can help gain greater bandwidth without upgrading hardware.
Link Aggregation Control Protocol (LACP)	A protocol used for realizing link dynamic aggregation. The LACPDU is used to exchange information with the peer device.
Link Aggregation Group (LAG)	Multiple physical Ethernet interfaces are combined to form a LAG, which increases the bandwidth and realizes load balancing.
Link-state tracking	Link-state tracking is used to provide interface linkage scheme for specific application and it can extend range of link backup. By monitoring uplinks and synchronizing downlinks, add uplink and downlink interfaces to a link-state group. Therefore, the fault of the upstream device can be informed to the downstream device to trigger switching. Link-state tracking can be used to prevent traffic loss due to failure in sensing the uplink fault by the downstream device.
Loopback	It is the process that a signal is sent out and then sent back to the sender. It is used to detect and analyze potential faults in a ring network.
M	
Maintenance association Intermediate Point (MIP)	MIP is the internal node of a service instance, which is automatically created by the device. MIP cannot actively send CFM packets but can forward and respond to Link Trace Message (LTM) and LoopBack Message (LBM).
Maintenance associations End Point (MEP)	MEP is an edge node of a service instance. MEPs can be used to send and process CFM packets. The MA and the MD where MEP locates decide the VLAN and the level for packets received and sent by MEP.
Mapping	A virtual data corresponding relationship
Message	In the data telecommunication field, the message structure is fixed. The header defines the destination address. The text is the real message. It can also include information used to stop the message.

Metropolitan Area Network (MAN)	<p>A high-speed computer network which connects multiple LANs within the effective distance in the urban region. The coverage of MAN is larger than that of LAN and smaller than that of WAN. The transmission medium is fiber and the MAN can be used as the backbone network.</p> <p>It is used to solve communication problems from BTS to BSC for 2G and from NodeB to RNC for 3G.</p> <p>In 2G times, mobile backhaul is realized through TDM microwave or SDH/PDH device since voice services play a primary role and there is no high requirement on the bandwidth.</p>
Mobile Backhaul	<p>In 3G times, IP services are involved since lots of data services like HSPA and HSPA+ exist, and voice services tend to change to IP services, that is, IP RAN. To solve mobile backhaul problems of IP RAN, you need to establish a backhaul network, which can meet requirements on both data backhaul and voice transmission over IP (clock synchronization).</p>
Multi-mode fiber	<p>In this fiber, multi-mode optical signals are transmitted.</p>

O

Optical Distribution Frame (ODF)	<p>A distribution connection device between the fiber and a communication device. It is an important part of the optical transmission system. It is mainly used for fiber splicing, optical connector installation, fiber adjustment, additional pigtail storage, and fiber protection.</p>
Optical power	<p>The work done by light within a time unit</p> <p>Units of optical power include mW and dBm, of which the former is a linear unit and the latter is a logarithmic unit. The relationship between the two units is: $P(\text{dBm})=10\text{Log}(P(\text{mW})/1\text{mW})$</p>
Packet switching	<p>In packet switching network, data is partitioned into multiple data segments. The data segment is encapsulated by control information, such as, destination address, to form the switching packet. The switching packet is transmitted to the destination in the way of storage-forwarding in the network. Packet switching is developed based on the storage-forwarding method and has merits of both circuit switching and packet switching.</p>
Protection switching	<p>It is a feature of transport entities. It can transmit traffic of a failed device or link to another device or link, which is a bidirectional feature. After you establish M protection lines for N ($1 \leq M \leq N$) working lines, when the working line fails, one of the M protection lines is determined according to the usage of locally saved protection lines and protocol signaling transmission, to replace the working line.</p>

Q

QinQ	<p>802.1Q in 802.1Q (QinQ), also called Stacked VLAN or Double VLAN, is extended from 802.1Q and defined by IEEE 802.1ad recommendation. This VLAN feature allows the equipment to add a VLAN tag to a tagged packet. The implementation of QinQ is to add a public VLAN tag to a packet with a private VLAN tag, making the packet encapsulated with two layers of VLAN tags. The packet is forwarded over the ISP's backbone network based on the public VLAN tag and the private VLAN tag is transmitted as the data part of the packet. In this way, the QinQ feature enables the transmission of the private VLANs to the peer end transparently. There are two QinQ types: basic QinQ and selective QinQ.</p> <p>A network security mechanism, used to solve problems of network delay and congestion. When the network is overloaded or congested, QoS can ensure that packets of important services are not delayed or discarded and the network runs high efficiently. Depending on the specific system and service, it may relate to jitter, delay, packet loss ratio, bit error ratio, and signal-to-noise ratio.</p>
Quality of Service (QoS)	
R	
Relative Humidity (RH)	Ratio of absolute humidity to saturated humidity in the air within a certain period, in unit of percentage
S	
Sensitivity	The minimum average input optical power received by the optical receiver when the frame loss rate of the fiber transceiver is zero in full-load data traffic conditions
Simple Network Management Protocol (SNMP)	A network management protocol defined by Internet Engineering Task Force (IETF) used to manage devices in the Internet. SNMP can make the network management system to remotely manage all network devices that support SNMP, including monitoring network status, modifying network device configurations, and receiving network event alarms. At present, SNMP is the most widely-used network management protocol in the TCP/IP network.
Single-mode fiber	In this fiber, single-mode optical signals are transmitted.
SyncE	A technology that adopts Ethernet link code stream to recover clocks, and provides high-precision frequency synchronization for the Ethernet similar to SDH clock synchronization. Different from the traditional network which just synchronizes data packets on the receiving node, the internal clock synchronization mechanism of the SyncE is real-time.
T	

Time Division Multiplexing (TDM)	TDM is a method of transmitting multiple independent signals (digitalized data, voice, or video signals) over a common signal path by means of synchronized switches at each end of the transmission line so that each signal appears on the line only a fraction of time in an alternating pattern.
Time To Live (TTL)	A technique used in best-effort delivery systems to prevent packets that loop endlessly. The TTL is set by the sender to the maximum time the packet is allowed to be in the network. Each router in the network decrements the TTL field when the packet arrives, and discards any packet if the TTL counter reaches zero.
Topology	Topology includes routes and devices, describing the interconnection relationship among network nodes. It also refers to the network structure in general sense, that is, the physical layout of connected devices.
V	
Virtual Private Network (VPN)	Network scheme in which portions of a network are connected via the Internet, but information sent across the Internet is encrypted. The result is a virtual network that is also part of a larger network entity. This enables corporations to provide telecommuters and mobile professionals with local access to their corporate network or to another ISP network. VPNs are possible because of technologies and standards such as tunneling, screening, encryption, and IPsec.

4.3 Acronyms and abbreviations

Numerics

3G 3rd-Generation

A

AC Alternating Current

ACL Access Control List

AN Access Node

APD Avalanche Photo Diode

APS Automatic Protection Switching

ATM Asynchronous Transfer Mode

B

BC	Boundary Clock
BITS	Building Integrated Timing Supply System
BSC	Base Station Controller
BTS	Base Transceiver Station
C	
CBS	Committed Burst Size
CC	Continuity Check
CCM	Continuity Check Message
CE	Conformite Europeenne
CE	Customer Edge
CES	Circuit Emulation Service
CFM	Connectivity Fault Management
CIR	Committed Information Rate
CLI	Command Line Interface
CoS	Class of Service
CRC	Cyclic Redundancy Check
D	
DC	Direct Current
DHCP	Dynamic Host Configuration Protocol
DLF	Destination Lookup Failure
DS	Differentiated Services
DSCP	Differentiated Services Code Point
E	
EFM	Ethernet in the First Mile
EIR	Excess Information Rate
E-LAN	Ethernet-LAN
E-Line	Ethernet-Line
ELPS	Ethernet Linear Protection Switching
EMC	Electro Magnetic Compatibility

ERPS	Ethernet Ring Protection Switching
E-Tree	Ethernet-Tree
ETS	European Telecommunications Standards
ETSI	European Telecommunications Standards Institute
G	
GPS	Global Positioning System
I	
IEEE	Institute of Electrical and Electronics Engineers
iTN	intelligent Transport Network
ITU-T	International Telecommunications Union - Telecommunication Standardization Sector
L	
LACP	Link Aggregation Control Protocol
LAN	Local Area Network
LB	Loop Back
LED	Light Emitting Diode
LLDP	Link Layer Discovery Protocol
LLDPDU	Link Layer Discovery Protocol Data Unit
LOS	Loss of Signal
LSA	Link State Advertisement
LT	Link Trace
M	
MAC	Medium Access Control
MDI	Medium Dependent Interface
MEF	Metro Ethernet Forum
MEP	Maintenance association End Point
MIB	Management Information Base
MIP	Maintenance association Intermediate Point

MP	Maintenance Point
MPLS	Multi Protocol Label Switching
MPLS-TP	Multi-Protocol Label Switching in Transport Networks
MTBF	Mean Time Between Failure
MTTR	Mean Time to Repair

N

NNI	Network Node Interface
NNI	Network to Network Interface
NNM	Network Node Management
NView NNM	NView Network Node Management

O

OAM	Operation, Administration and Management
ODF	Optical Distribution Frame

P

PC	Personal Computer
PDH	Plesiochronous Digital Hierarchy
PDU	Protocol Data Unit
PIN	P type-intrinsic-n type
POS	Packet Over SDH
PSN	Packet Switched Network
PTN	Packet Transport Network
PVC	Permanent Virtual Circuit
PW	Pseudo Wire
PWE3	Pseudo Wire Emulation Edge-to-Edge

Q

QoS	Quality of Service
-----	--------------------

R

RADIUS	Remote Authentication Dial In User Service
RED	Random Early Detection
RH	Relative Humidity
RNC	Radio Network Controller
RoHS	The Restriction of the Use of Certain Hazardous Substances in Electrical and Electronic Equipment
ROS	Raisecom Operating System
S	
SDH	Synchronous Digital Hierarchy
SFP	Small Form-factor Pluggable
SLA	Service Level Agreement
SNMP	Simple Network Management Protocol
SP	Strict-Priority
SSHv2	Secure Shell v2
T	
TACACS	Terminal Access Controller Access Control System
TDM	Time Division Multiplex
TDMoP	Time Division Multiplex over Packet
TLV	Type Length and Value
ToS	Type of Service
TTL	Time to Live
U	
UL	Underwriter Laboratories
V	
VCSEL	Vertical Cavity Surface-Emitting Laser
VLAN	Virtual Local Area Network
VPN	Virtual Private Network

W

WCDMA	Wideband Code Division Multiple Access
WRED	Weighted Random Early Detection
WRR	Weight Round Robin

